



AUTOMATIC BALING PRESS



TB-0911 SERIES

FEATURES OF HORIZONTAL BALING PRESS

- ▶ Suitable for professional recycling center, printer, paperboard factory especially with high capacity demand and large scale.
- ▶ Can compress larger papers such as carton box, corrugated paper, cardboard.
- ▶ Press force from 65~80 tons, capacity from 5~13 Tons per hour.
- ▶ Bale size is 1050(W)*750(H)*Variable(L), Bale weight can up to 850kg.
- ▶ Recommended to equip with automatic ruffler for magazine or newsprint to make bale tightly.
- ▶ Can equip the conveyor, air cyclone, excavator to feed the waste materials.
- ▶ The position of operation panel and shape of hopper can be modified to satisfy the real demand of customer.
- ▶ All operation and monitoring function are controlled through a programmable logic controller(PLC).
- ▶ Exclusive auto-tier system.
- ▶ The strong and rigid structure is reliable and optimum for less maintenance.



TB-0911 SERIES

Machine dimension

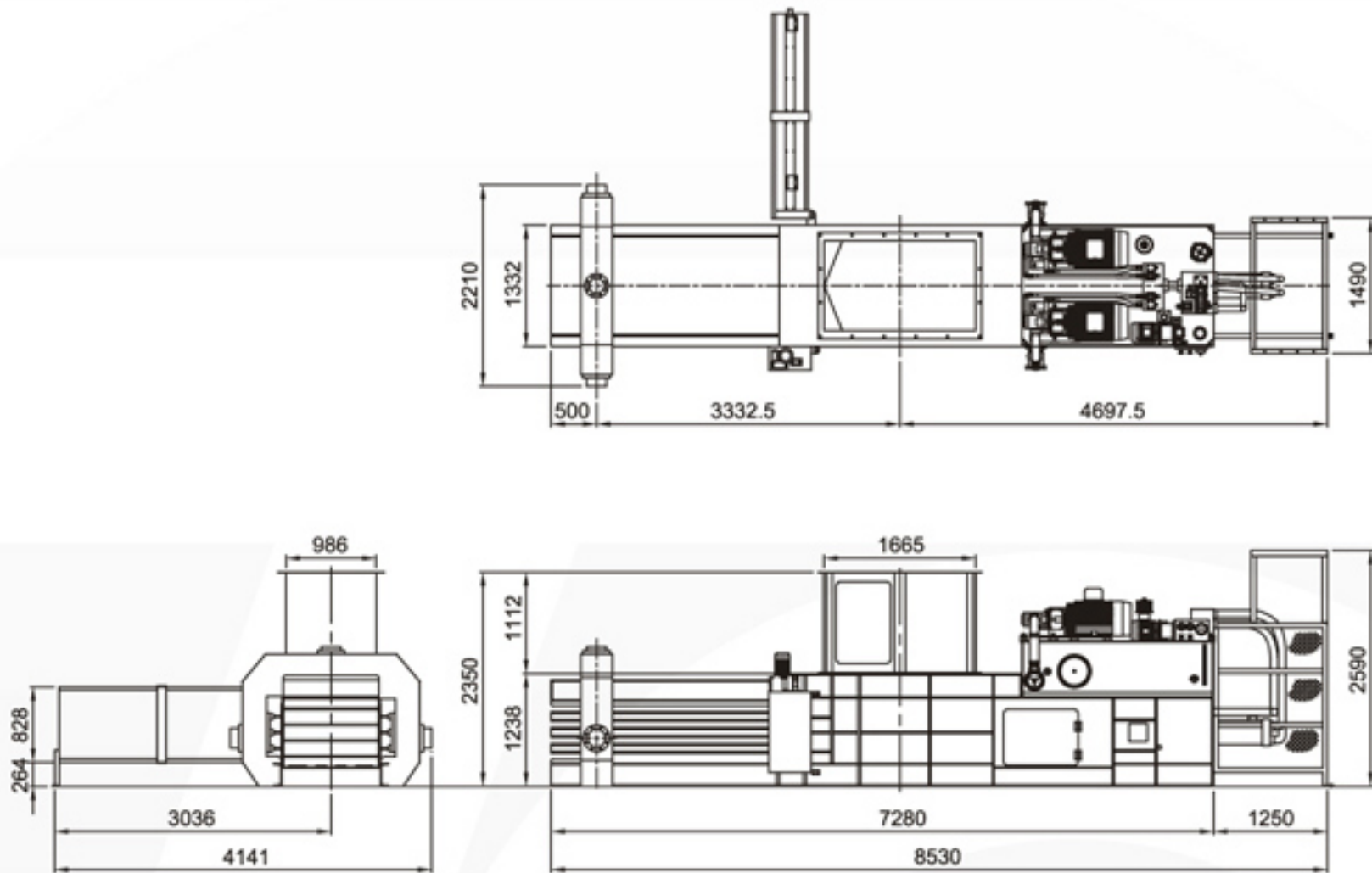



Specifications

MODEL	APERTURE	BALE SIZE (mm)	MOTOR		WIRE TIE (Fold)	PRESS FORCE (Tons)	CAPACITY (Tons/Hr)	BALE WEIGHT	
	(mm)		HP	KW					
TB0911H0/9	W=986mm L=1665mm	W=1050mm H=750mm L=Variable	50*2	37*2	4 Horizontal	80	11~13	Up to 850kg	
TB091180/9			40*2	30*2			9~11		
TB091160/9			60*1	45*1			8~10		
TB091150/9			50*1	37*1			6~8		
TB091140/9			40*1	30*1			5~7		
TB091180/8			40*2	30*2		11~13	65		Up to 750kg
TB091160/8			60*1	45*1		9~11			
TB091150/8			50*1	37*1		7~9			
TB091140/8			40*1	30*1		6~8			



TECHGENE MACHINERY CO.,LTD

Sales Representative: Kevin Hsu
 Sales Contact: Joey Kuo
 Address: No.10, Alley 49, Lane 535, Section 2, Fong Shih Rd.
 Fong Yuan City, Taichung, Taiwan
 TEL: 886-4-25285670 FAX: 886-4-25293196
 Email: kevin@techgene.com.tw
 joey47@techgene.com.tw
 Web: <http://www.techgene.com.tw>
<http://www.1>    [m.tw](http://www.1m.tw)

