

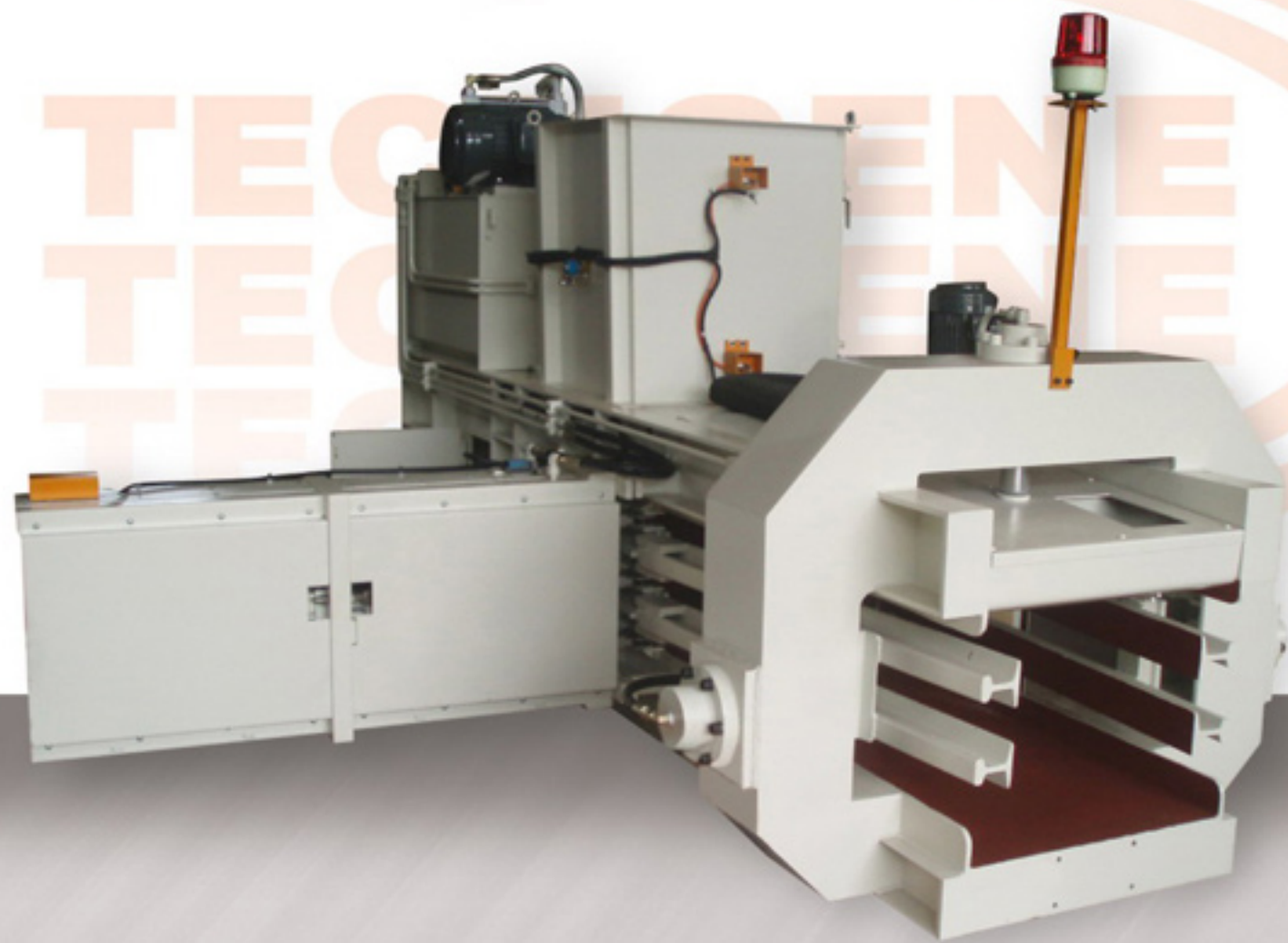

AUTOMATIC BALING PRESS



TB-0505 SERIES

FEATURES OF HORIZONTAL BALING PRESS

- ▶ Suitable for recycling collector, paper makers especially with the finite place and the lower output demand.
- ▶ Can compress scrap paper and plastic films.
- ▶ Press force up to 25 tons, capacity from 1~1.5 Tons per hour
- ▶ Bale size is 550(W)*550(H)*Variable(L), Bale weight can up to 200kg.
- ▶ Can equip the conveyor, air cyclone, excavator to feed the waste materials.
- ▶ The position of operation panel and shape of hopper can be modified to satisfy the real demand of customer.
- ▶ All operation and monitoring function are controlled through a programmable logic controller(PLC).
- ▶ Exclusive auto-tier system.
- ▶ The strong and rigid structure is reliable and optimum for less maintenance.



TB-0505 SERIES

Machine dimension

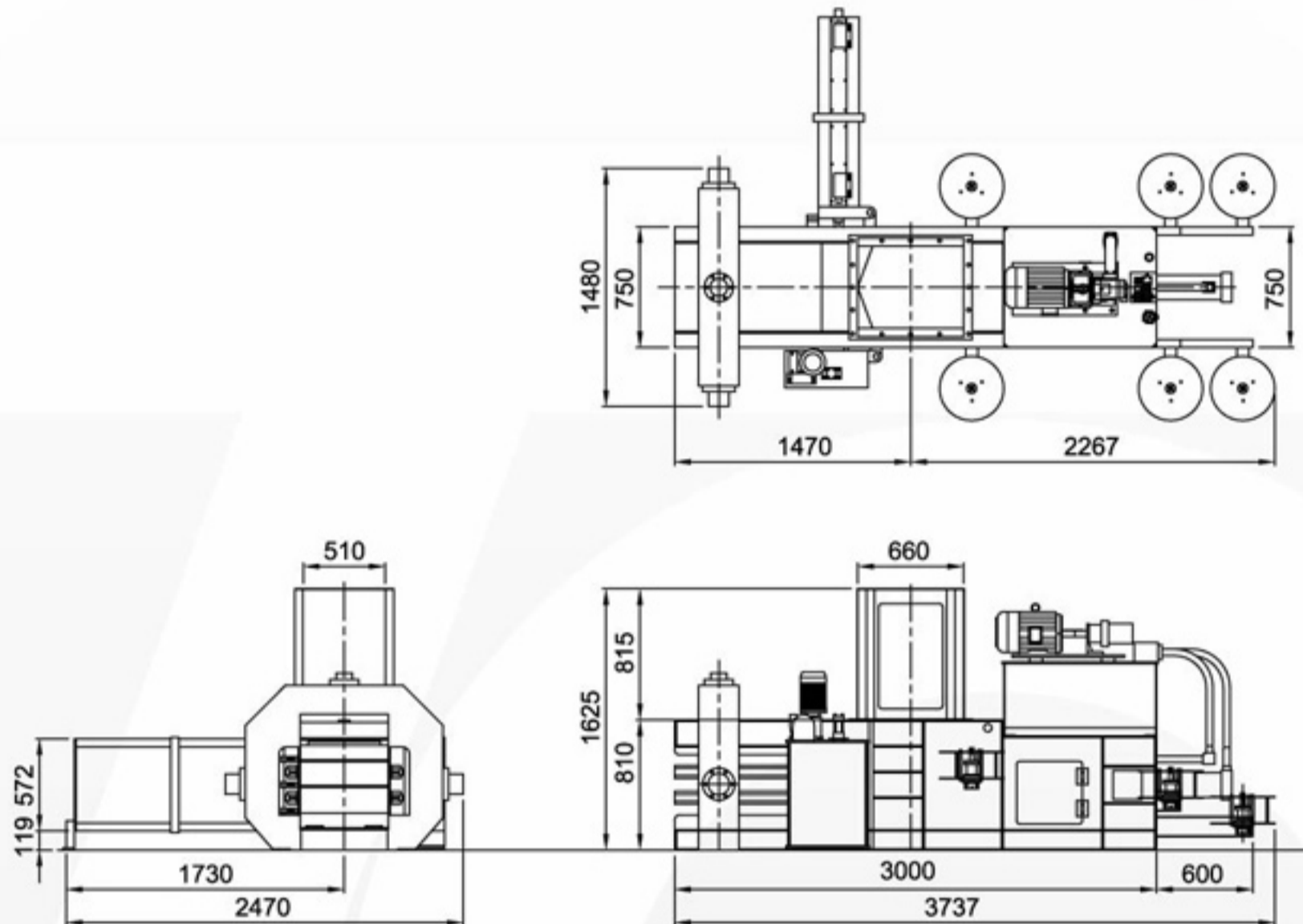

Specifications

MODEL	APERTURE	BALE SIZE	MOTOR		WIRE TIE	PRESS FORCE	CAPACITY	BALE
	(mm)	(mm)	HP	KW	(Fold)	(Tons)	(Tons/Hr)	WEIGHT
TB050510/5	L=660mm	W=H=550mm	10	7.5	3	25	1.5	Up to 200kg
TB050508/5	W=510mm	L=Variable	7.5	5.5	Horizontal		1	



TECHGENE MACHINERY CO.,LTD

Sales Representative: Kevin Hsu
 Sales Contact: Joey Kuo
 Address: No.10, Alley 49, Lane 535, Section 2, Fong Shih Rd.
 Fong Yuan City, Taichung, Taiwan
 TEL: 886-4-25285670 FAX: 886-4-25293196
 Email: kevin@techgene.com.tw
 joey47@techgene.com.tw
 Web: <http://www.techgene.com.tw>
<http://www.techgene.com.tw>

